

CURTAIN NIPPLE

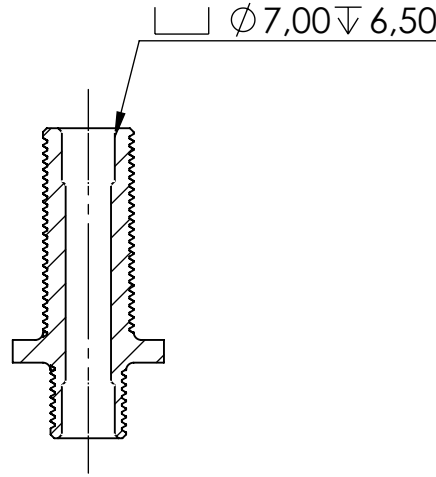

SECTION U-U

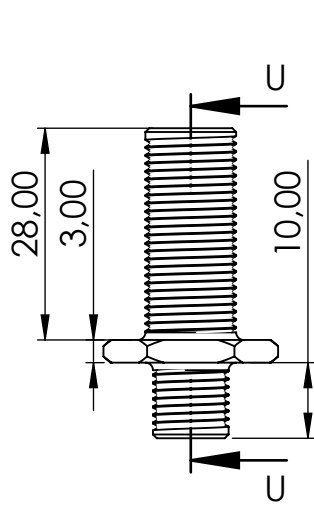
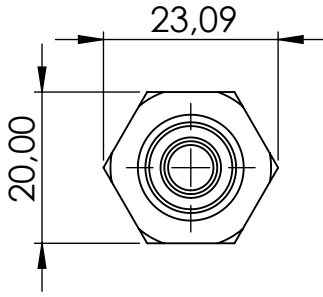
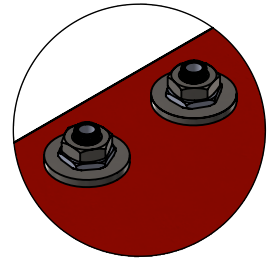
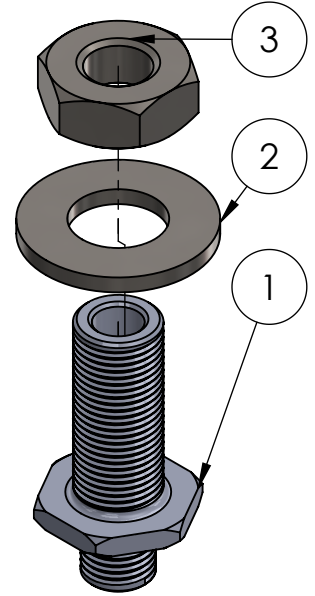
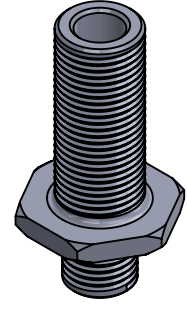

DETAIL A

ASSEMBLY PARTS	
1	CURTAIN NIPPLE
2	FLAT WASHER M12
3	NUT M12

NOTE: NOT FOR ONLY USE, PART OF RELEASE STATION (POS.5) AS SHOWN AS "DETAIL A"
NOTE: ALL DIMENSIONS ARE GIVEN AS MILLIMETERS

DRAWING NO:	POS. NO. 5_3	PROUDCT NO: AL20-40068	DATASHEET: AL20-40068 Rev00	PAGE A4
DESIGNED BY: ALİ ARMAĞAN	CHEKED BY: ÇAĞLAR LATİFOĞLU	APPROVED BY: ERDİNÇ LATİFOĞLU	DATE: 14/09/2020	SCALE: 1:3



PROJECT / PROUDCT: CURTAIN NIPPEL

WEIGHT: -	METARIAL: -	REVISION: Sept20-Rev00	SHEET 1
-----------	-------------	------------------------	---------