



1. GENERAL & APPLICATIONS

Marine certified conventional flame detector, detector is a point type flame detector which is a full featured solar blind flame detector for indoor use and boasts a high degree of false alarm immunity. The flame detector is designed for connection to a conventional zone of point type fire detectors that may include any mix of detection Technologies, it also has a fast respons to flame and can detect a 0.1m² fire at a range of 20m. The flame detector contains an Integral alarm LED with 360 degree angle of view and also fits a standard point fire detector base.



2. INSTALLATION

- I. Loop cabling is connected to base terminals as follows: L -VE IN/OUT
- II. L1 +VE IN
- III. L2 +VE OUT
- IV. R Remote LED Drive

2.1. DETECTOR BASE

The base should be fixed such that the park plunger faces toward the door or trafficable area. This ensures the detector LED will be visible from the direction of entry, in accordance with AS1670.1-2004. The 5B base should be located as shown on the site plan, fixed to a suitable flat surface strong enough to take the weight of the base and detector.

Two pan head screws 4.8mm diameter (max.) are required (not supplied) for fixing the base. The base may be fixed directly to the ceiling, to a conduit box, DHM5B deckhead mount or Euro Mount base. To aid fixing, there are enlarged holes in the base allowing a screw to be started, then the base inserted over the screw head and rotated on the screw to be held loosely on the ceiling. The second screw can then be installed and both screws tightened. The 5B base has four electrical contacts which align with the contacts on the detector once the latter is fitted and fully latched into position.

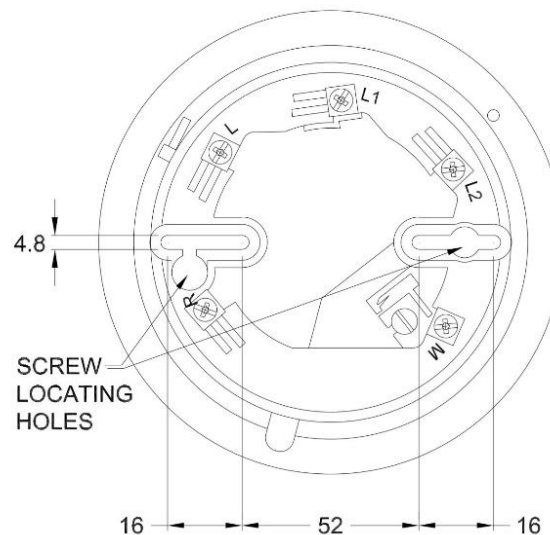



WIRING—Collective Cables are connected to base terminals L (-In/Out) and L1 (+ In) and L2 (+Out) for Collective systems. A Remote Indicator may be connected between positive L1 (+) and R (-).

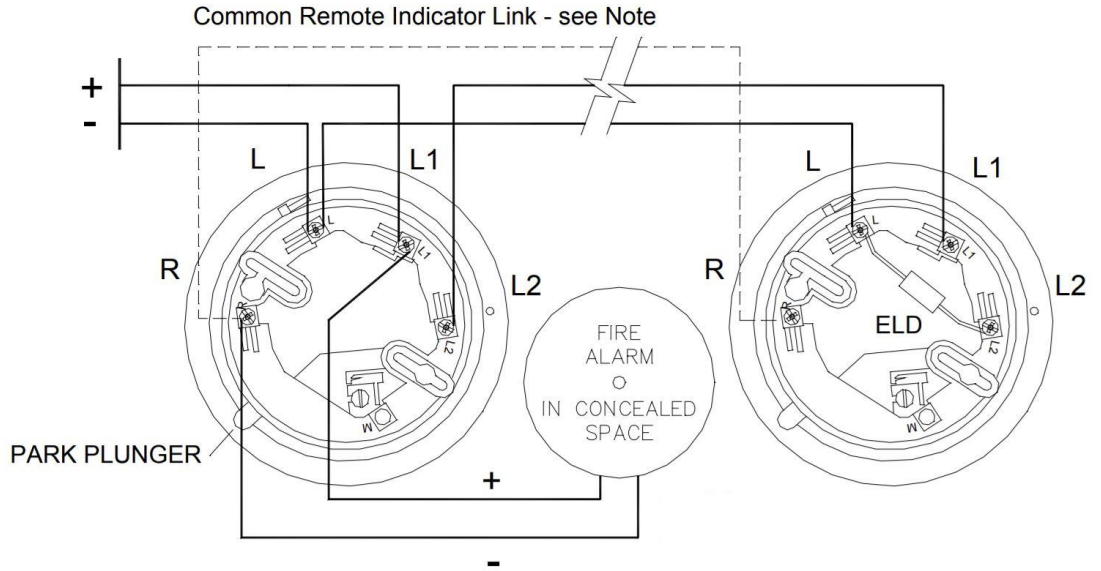

5B Base Wiring—Collective Systems

3. TECHNICAL PROPERTIES

3.1. CICUIT OPERATIONS

A simplified block schematic of the circuit is given in Fig. 2.

The infra-red radiation passing through the narrow-band filters falls on a pyroelectric sensor which responds to the flickering component of the radiation. The electrical signal produced is amplified and filtered, to remove frequencies outside the required flicker region.

The threshold detector and signal processor evaluate the amplitude and frequency characteristics of the flicker. If the flicker signal is above the preset threshold for three seconds, the output latch is triggered to light the internal LED alarm indicator. The increased current drawn from the line signals the alarm condition to the control unit.

All critical parts of the circuit are fed by an internal voltage regulator to make the sensitivity independent of supply over a wide range.

The facility for a remote LED indicator is available without the need for additional circuitry.

Two +ve terminals are provided to allow the monitoring of the circuit wiring through the detector.

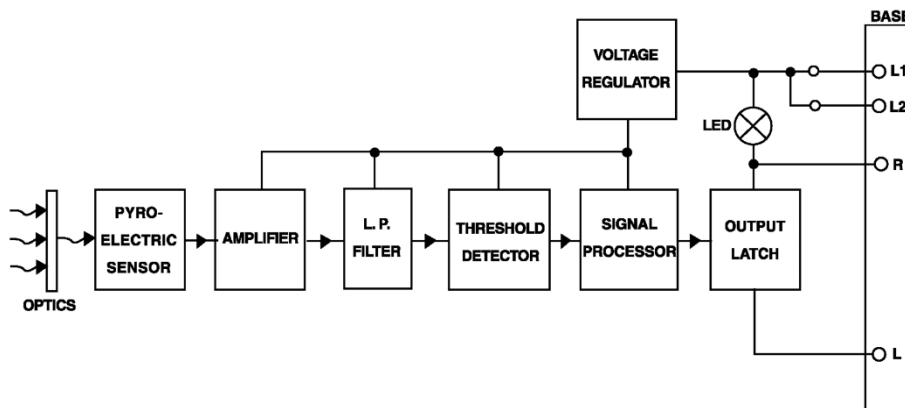

Fig. 2 Simplified Block Schematic Diagram of Detector



3.2. ELECTRICAL CHARACTERISTICS

Table 1 shows the electrical characteristics, these are taken at 25°C with an operating voltage of 20V unless otherwise specified. The alarm load presented to the controller by the detector is shown in Fig. 4.

Characteristics	Min.	Typ.	Max.	Unit
Operating Voltage (dc)	18		28	V
Quiescent Current	150	300	350	µA
Switch-on-Surge		850	1000	µA
Stabilisation Time			30	sec
Alarm Current	36mA @ 18V 42mA @ 20V 70.5mA @ 31V			mA
Holding Current			1	mA
Holding Voltage			5	V
Reset Time	1/2	1	2	sec
Remote LED drive	via a 3.4		k resistor	

Table. 1 Electrical Characteristics

3.3. ENVIRONMENTAL

Operating Temperature: -20°C to +70°C but see note below.

Storage Temperature: -40°C to +80°C

Note: Operation below 0°C is not recommended unless steps are taken to eliminate condensation and hence ice formation on the detector.

Relative Humidity

Operational: 90% RH continuous (non-condensing) and up to 99% RH intermittent (non-condensing)

Storage: >40% RH and <70% RH

Shock: To EN54 Part 10

Vibration: To EN54 Part 10

Impact: To EN54 Part 10

Corrosion: To EN54 Part 10

3.4. MODE OF OPERATION BEHAVIOUR FIRE TEST

The operating principles of the detector have been described in Section 3 and the information given below is intended to supplement this basic description.

It has already been noted that the detector analyses the signal flicker frequency and produces an alarm if the level is above a preset threshold for three seconds. It is worth stressing that if the signal is below this threshold the detector will not respond even after a long time.

The level of the signal received depends on the size of the flame and its distance from the detector. For liquid fuels the level is almost proportional to the surface area of the burning liquid. For any type of fire, the signal level varies inversely with the square of the distance.



Fire tests are normally carried out using liquid fuels, burning in pans of known area. The sensitivity of a detector is then expressed as the distance at which a particular fire size can be detected.

It is important to think in terms of distance rather than time because of the burning characteristics of different fuels. Fig. 4 shows the typical response of two different fuels which ultimately produce the same signal level. The signal level given by n-heptane quickly reaches its maximum, and produces an alarm in approximately six (6) seconds after ignition. Diesel, being less volatile, takes approximately sixty (60) seconds to reach equilibrium burning state and an alarm is given approximately fifty-five (55) seconds after ignition.

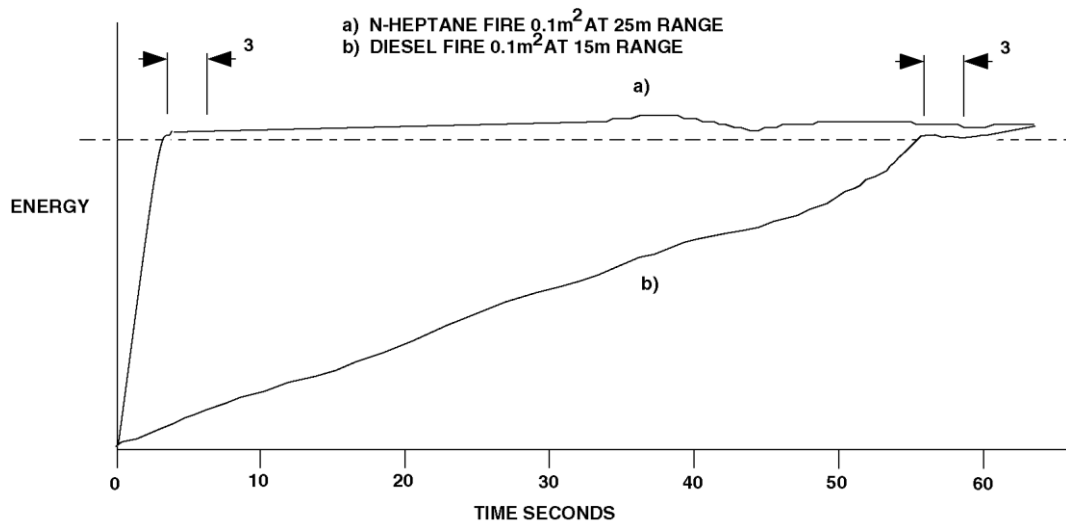

Fig. 4 Typical Response to Fires

The time taken by the fire to reach equilibrium depends on the initial temperature of the fuel. If diesel is pre-heated to a temperature above its flash point, then it behaves the same as n-heptane at 25°C. The fire test data presented in Section 5.2 refers to fires which have reached their equilibrium condition. The range specified is that obtained with the detector axis horizontal and with the fire on the detector axis.

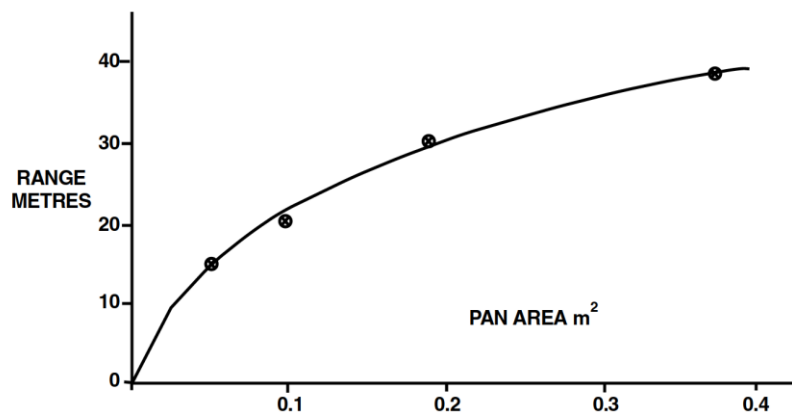

Fig. 5 Typical Detector Range vs Pan Area - n-heptane



3.5. FIRE TEST DATA

3.5.1. N HEPTANE

The most convenient fuel for fire tests is n-heptane since it is readily available and quickly reaches its equilibrium burning rate. The range figures specified in Section 5.2.2 relate to a n-heptane fire in a 0.1m² pan on the main axis of the detector field of view.

The graph in Fig. 5 shows the typical detection ranges as a function of pan area for n-heptane fires. It will be seen that this curve is approximately a square law; that is to say that to obtain detection at twice the distance the pan area must be multiplied by four.

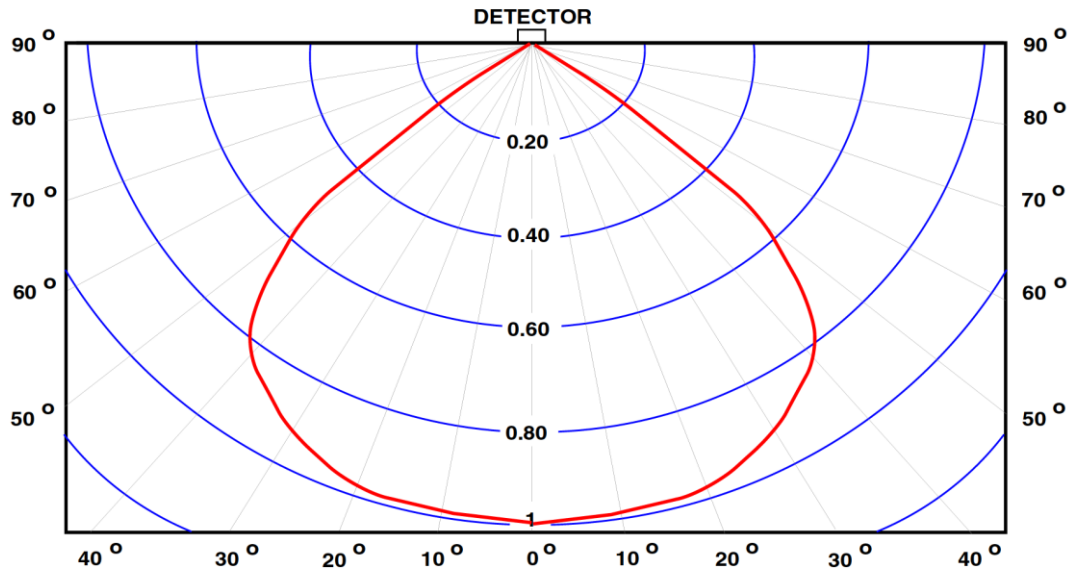

Fig. 6 Relative Range vs Angle of Incidence

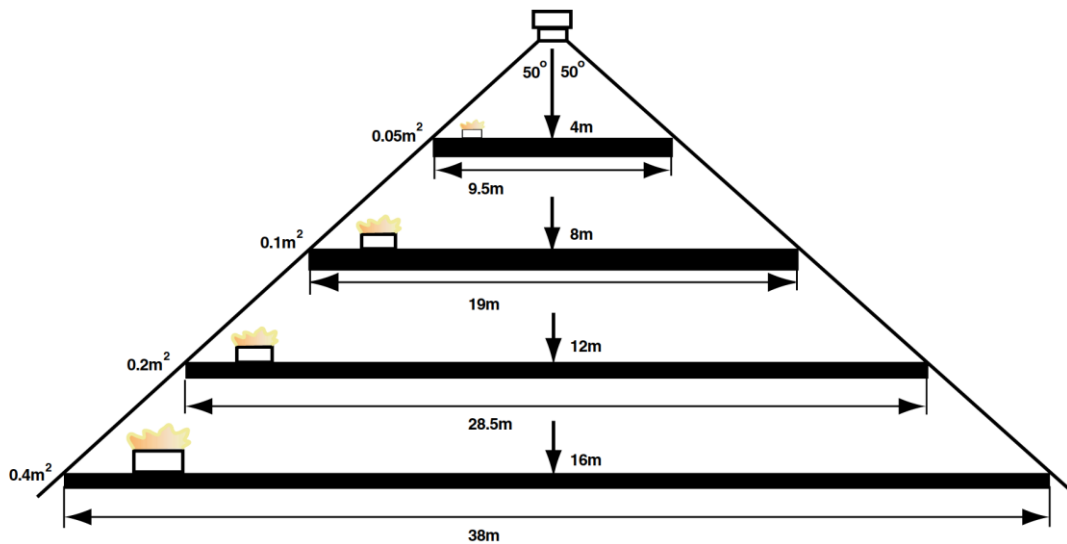

Fig. 7 Field of View



3.5.2.DETERMINING THE NUMBER OF DETECTORS

The number of detectors required for a particular risk will depend on the area involved and the fire size at which detection is required. Large areas or small fires require large numbers of detectors.

As there are no agreed 'rules' for the application of flame detectors, the overall system sensitivity must be agreed between the designer and the end user. When agreement has been reached the system designer can determine the area to be covered by each detector using the fire test data.

The detector is designed primarily for ceiling mounting with its axis vertically downwards. When used in this way it will cover a circular area at ground level, the diameters of the circle being proportional to the height.

Under these conditions the effective sensitivity is that which is achieved at the edge of this circular area taking into account the slant range and the angle of incidence.

Fig. 6 shows the effective sensitivity for n-heptane fires when used in this configuration.

Note: Any object within the detector's field of view will cause a 'shadow' in the protected area. Small objects close to the detector can cause large shadows.

4. MAINTANANCE

EVERY 3 MONTHS

Always be sure that detector is clean, no scratch, damage or broken parts.

All connection must be done properly.

Turn detector clock wise and remove detector from detector base. On the back be sure that connection lugs and inside back clean(No oil, dust, undefined liquids)

5. DIMENSION & TECHNICAL DRAWINGS

L.A.S. FLAME DETECTOR

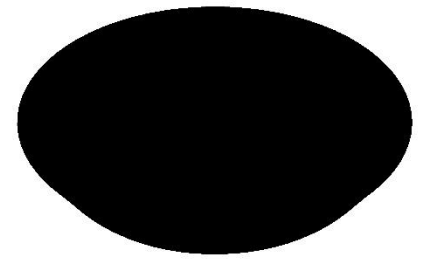
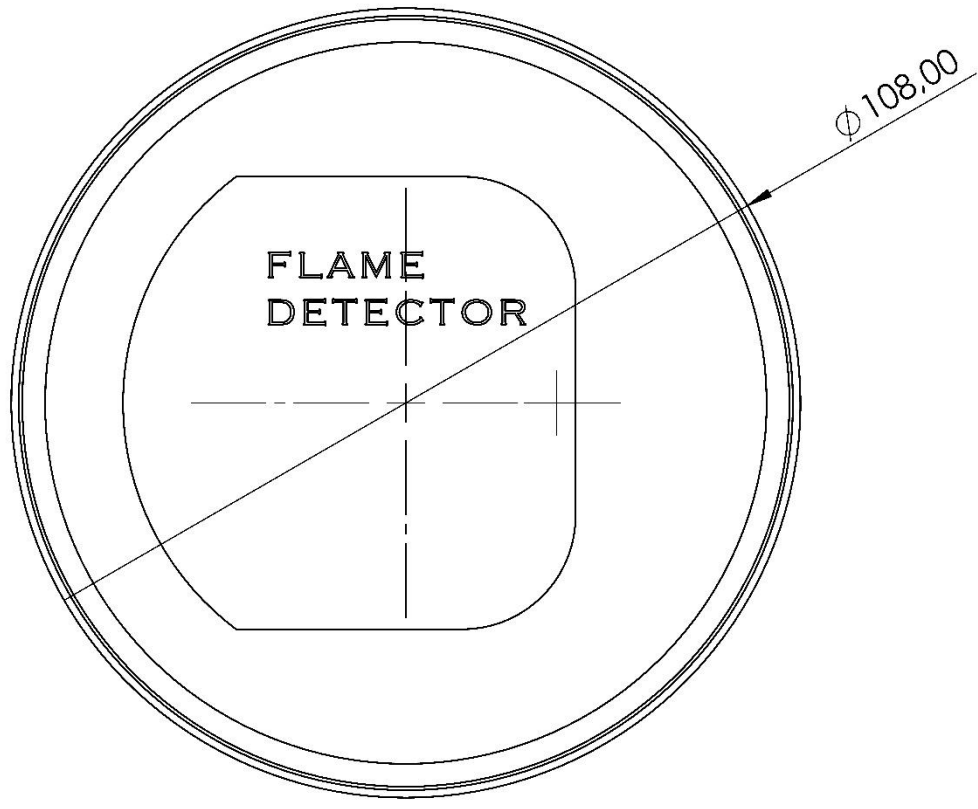
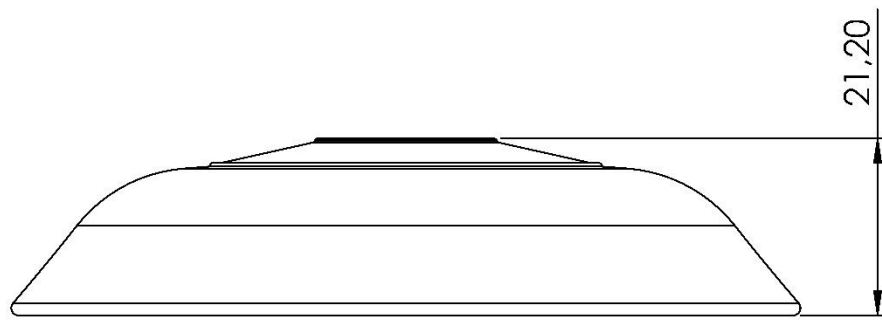

DRAWING NO:	POS. NO. -	PROUDUCT NO: 516.600.007	DATASHEET: 516.600.007.Rev00	PAGE A4
DESIGNED BY: ALİ ARMAĞAN	CHEKED BY: ÇAĞLAR LATİFOĞLU	APPROVED BY: ERDİNÇ LATİFOĞLU	DATE: 17/12/2020	SCALE: 1:1
		PROJECT / PROUDUCT: LOCAL APPLICATION SYSTEM SECTION VALVE WITH ELECTRICAL ACTUATOR		
		WEIGHT: 74g	METARIAL: -	REVISION: DEC20-Rev00
				SHEET 1