

DOCUMENT CONTROL NUMBER /

601H-R/601H-R-M / 601H-F/601H-F-M HEAT DETECTORS

PRODUCT APPLICATION AND DESIGN INFORMATION

1. INTRODUCTION

The 601H-R/601H-F Heat Detectors form part of the Series 600 range of plug in detectors for ceiling mounting. The detector plugs into the Minerva MUB, 5B 5" Universal Base or 5BD 5" Conventional Continuity Base and is intended for two-wire operation with the majority of control equipment currently manufactured by the company.

The 601H-R-M / 601H-F-M are the Marine versions of the 601H-R/601H-F.

2. OPERATING PRINCIPLE

The 600 range of heat detectors includes both Rate-of-Rise and Static (fixed temperature) types. These detect abnormally high rates of rise of temperature and abnormally high temperatures respectively. One of each type is offered within the range to cater for differing applications. The basic operating principles and construction are described below.

2.1 CIRCUIT DESCRIPTION - EN54-5 CLASSIFICATION A1R

A simplified block schematic of the 601H-R Rate-of-Rise detector is given in Fig. 1.

Two negative temperature coefficient thermistors, R_{sens} and R_{ref} are used in a bridge configuration as shown. One thermistor, R_{sens} , is exposed to the air whilst the other, R_{ref} , is

thermally lagged inside the detector body. If the temperature of the air around the detector rises quickly, a temperature difference will be established between R_{sens} and R_{ref} . The values of the bridge components are chosen such that, if a particular rate of change of temperature is sustained for sufficient time, the comparator will change state and the detector will signal an alarm condition.

If the rate of temperature increase is very slow, then the temperatures of the sensing and reference thermistors will be more nearly equal. Under these conditions the bridge components ensure that the comparator changes state when the predetermined fixed temperature is reached.

The Rate-of-Rise detector has a rate sensitivity and fixed (static) temperature setting to suit a particular type of application.

2.2 FIXED TEMPERATURE EN54-5 CLASSIFICATION A1S

The Fixed Temperature detector 601H-F 'A1S' is similar to the 'A1R' detector except that the reference thermistor is replaced by a fixed resistor. The detector, therefore, responds more slowly to Rate-of-Rise of temperature. The bridge components are chosen instead to cause the comparator to change state when the sensing thermistor reaches a predetermined temperature irrespective of the rate of change.

The static temperature is 54°C to 65°C.

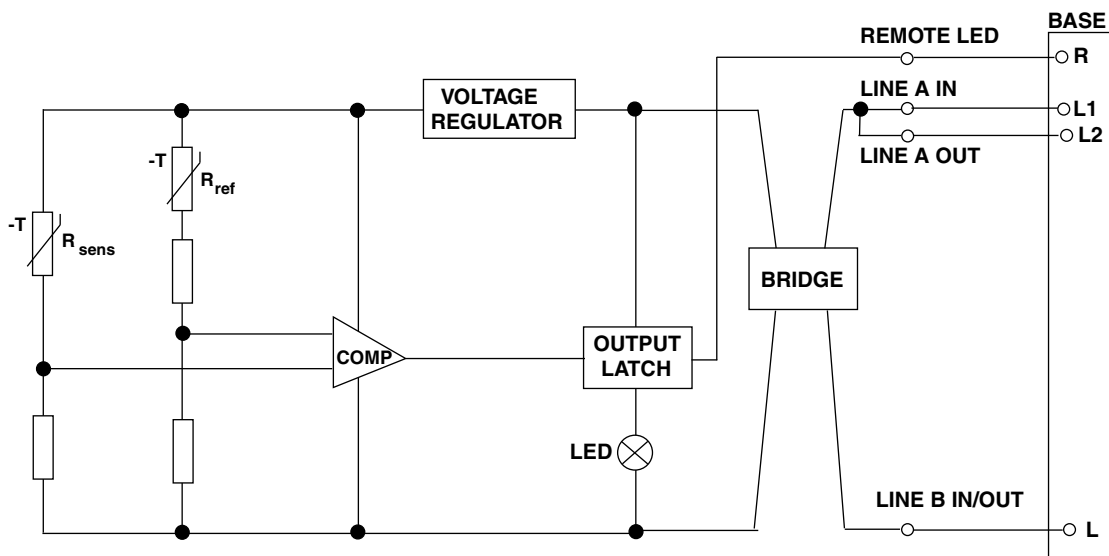

Fig. 1 Simplified Block Schematic Diagram



SERIES 600

01C-02-D5

2 11/03

2.3 WIRING

The detector circuit requires a positive and negative supply and these are wired to terminals L1 and L on the base (see Fig. 1). The bridge circuit in the detector makes the detector polarity insensitive. Base terminal L1 is connected to base terminal L2 when the detector is fitted to provide continuity monitoring through the detector. Base terminals L2 and L provide outputs to the next detector or EOL device.

A drive is provided for a remote indicator connected between supply +ve and terminal R, therefore, at a detector where a remote indicator is connected, the polarity of the supply must be known.

3. MECHANICAL CONSTRUCTION

The major components of the detector are:

- Body Assembly
- Printed Circuit
- Thermistors
- Light Pipe
- Inner Cover
- Outer Cover

3.1 ASSEMBLY

The body assembly consists of a plastic moulding which has four embedded detector contacts aligning with contacts in the MUB, 5B or 5BD base. The moulding incorporates securing features to retain the detector in the base.

Four PCB mounted spring contacts provide electrical connection between the detector contacts and the PCB.

The light pipe is slotted into the inner cover which is then clipped to the body. Finally, the outer cover is clipped to the body.

3.2 FINAL ASSEMBLY

The sensor housing is fitted to the body assembly. Finally, the outer cover is snapped into position on the body to provide mechanical protection to the otherwise exposed sensing thermistor.

4. TECHNICAL SPECIFICATION

The detectors in the 600 range differ mainly in their response characteristics. Unless otherwise specified, the information given below applies to all types.

4.1 MECHANICAL

Dimensions

The overall dimensions are shown in Fig. 2

Material

Body and cover: FR110 'BAYBLEND'
fire resistant

Weight

Detector: 0.08kg
Detector plus Base: 0.13kg

4.2 ENVIRONMENTAL

Storage Temperature: -25°C to +80°C
Temperature Long-Term: -20°C to +70°C
Temperature Short-Term (<3min.): -40°C to +120°C

Note: The maximum temperatures quoted are those at which the detector may sustain permanent damage. Maximum ambient temperatures at which detectors may be used, without high false alarm rates, are dependent upon detector type.

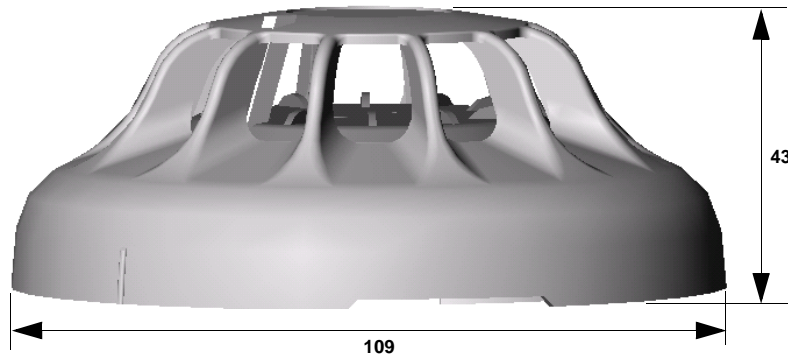

Fig. 2 600H Series - Overall Dimensions



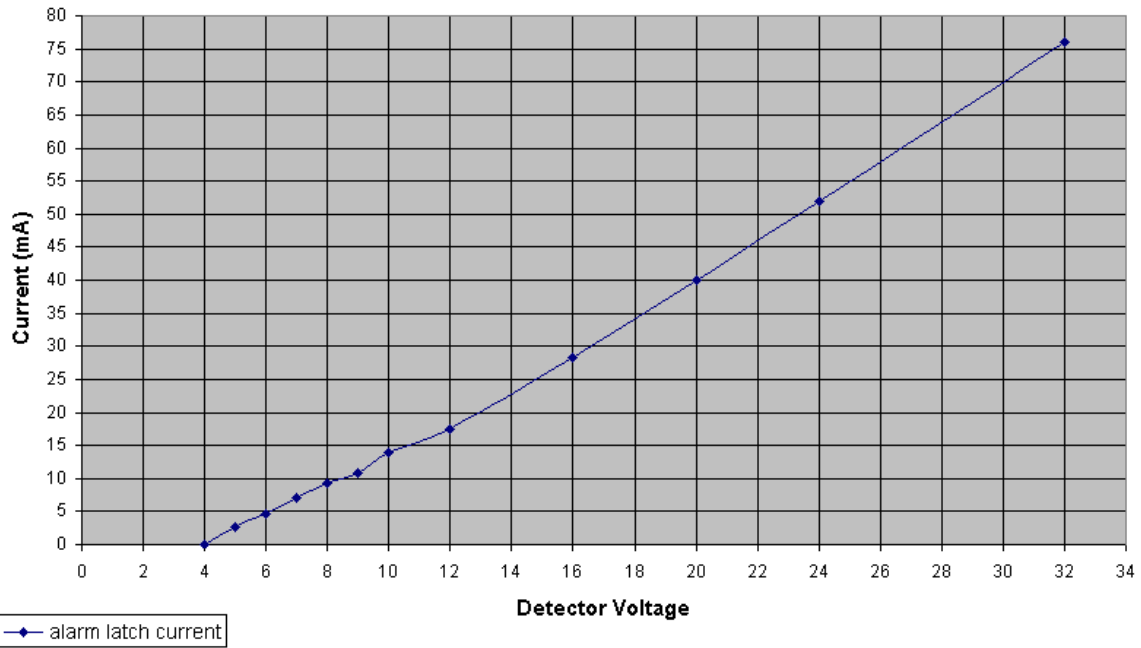

Fig. 3 601H-F

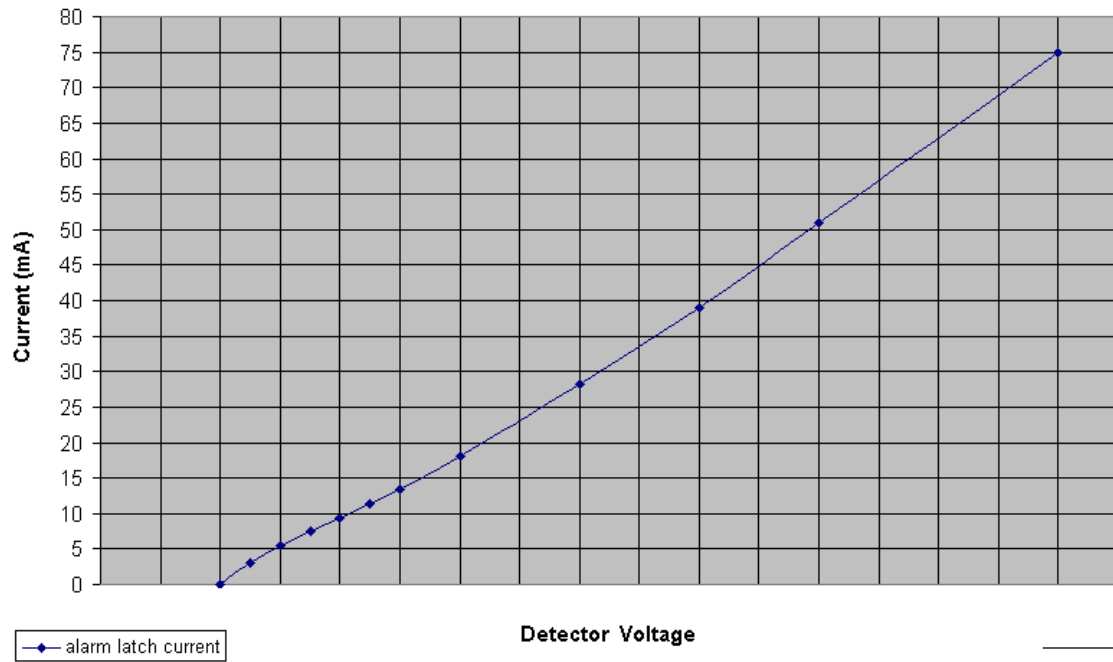

Fig. 4 601H-R

Relative Humidity: 95% non-condensing

Shock:

Vibration:

Impact: To EN54-5

Corrosion:

4.3 ELECTROMAGNETIC COMPATIBILITY

The detector complies with the following:

Product family standard EN50130-4 in respect of
 Conducted Disturbances, Radiated Immunity,
 Electrostatic Discharge, Fast Transients and Slow High
 Energy
 EN50081-1 for Emissions



SERIES 600

01C-02-D5

2 11/03

4.4 ELECTRICAL CHARACTERISTICS

Table 1 shows the electrical characteristics. These are taken at 25°C with an operating voltage of 24V unless otherwise specified. The alarm load presented to the controller by the detectors is shown in Figs. 3 & 4.

4.5 PERFORMANCE CHARACTERISTICS

4.5.1 GENERAL

The performance of Heat Detectors is normally specified in two ways. These are:

- The 601H-R meets the requirements for the EN54-5 classification for A1R.
- The 601H-F meets the EN54-5 classification A1S.

CHARACTERISTIC	MIN.	TYP.	MAX.	UNIT
Operating Voltage (dc)	10.5	24	33	V
Quiescent Current	57	65	82	µA
Switch-on Surge			90	µA
Stabilisation Time		1		sec
Alarm Current	See Fig. 3			mA
Holding Current		3		mA
Holding Voltage		5		V
Reset Time		2		sec
Remote Led Drive	via 1k resistor			

Table 1: 601H-R Electrical Characteristics

CHARACTERISTIC	MIN.	TYP.	MAX.	UNIT
Operating Voltage (dc)	10.5	24	33	V
Quiescent Current	57	61	82	µA
Switch-on Surge			90	µA
Stabilisation Time		1		sec
Alarm Current	See Fig. 4			mA
Holding Current		3		mA
Holding Voltage		5		V
Reset Time		2		sec
Remote Led Drive	via 1k resistor			

Table 2: 601H-F Electrical Characteristics

5. DETECTOR IDENTIFICATION

The detector is identified by the logo label as shown in Fig. 5.

ADT Variants

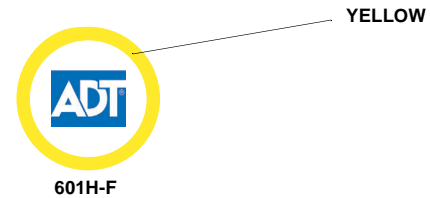
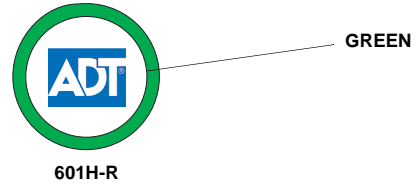

Thorn Variant

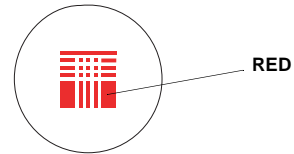

Tyco Variant (Tyco Blue)



Tyco Marine Variant (Black)

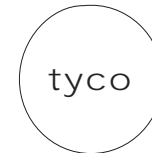

Fig. 5 Detector Identification

6. ORDERING INFORMATION

Heat Detector Type 601H-R (A1R):	516.600.003.A/T/Y
Heat Detector Type 601H-F (A1S):	516.600.013.A/T/Y
Marine Heat Detector Type 601H-R-M	516.600.203
Marine Heat Detector Type 601H-F-M	516.600.213
MUB Base:	517.050.001
5B 5" Universal base:	517.050.017
5BD 5" Conventional Continuity Base:	517.050.600

MK/pln

14th November 2003

